

PERFORMIX® 640L MIXER (PM170)

Master your mud mixing with the Performix® Mixing System.

The Performix® PM170 generates 640 litres per minute through the venturi to get your mud sheared and yielded faster.

SPECIFICATIONS:

Engine:

Kohler Command CS Pro 7 HP (4.5 KW) gas engine w/heavy duty cyclonic air cleaner and pull-start

Pump:

643 LPM designed to turn tank over in less than 2 minutes

Fuel Tank:

23 L fuel tank for extended run time between refueling

Hopper:

Large capacity with pivoting lid that doubles as a bag rest

Jet:

Field-proven high-speed jet and venturi produce sheared and yielded mud in a matter of minutes

Mechanical Seal:

N/A

Connections:

51 mm suction and discharge ports w/ball valves

Mounting:

Adapts easily to any truck or trailer

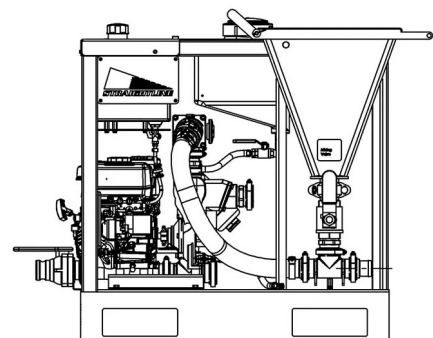
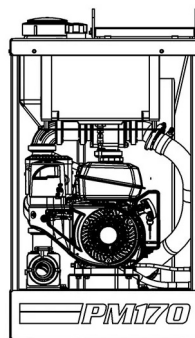

L	W	H
610mm	991mm	1067mm



Pair the Performix PM170 with the new SL500 1892L Yield Tank for maximum performance

For more information, talk to us today

AUSTRALIA
03 9068 5688

NEW ZEALAND
07 849 2366

sales@blick.group
www.blick.group

