

PERFORMIX® 1380L MIXER (PM365)

Master your mud mixing with the Performix® Mixing System.

The Performix® Mixer generates 1,380 litres per minute through the venturi to get your mud sheared and yielded faster.

SPECIFICATIONS:

- hour meter
- oil drain tube
- antifreeze tank

Engine:

Kohler® Command CS Pro 14 HP (10.5 KW) gas engine w/heavy duty cyclonic air cleaner and electric start

Pump:

1380 LPM designed to turn tank over in less than 3 minutes

Fuel Tank:

23 L fuel tank for extended run time between refueling

Hopper:

Large capacity with pivoting lid that doubles as a bag rest

Jet:

High-speed jet effectively shears the bentonite plates, producing the highest possible yield

Mechanical Seal:

Runs in antifreeze so the seal is constantly lubricated (the pump can be run dry without damaging the seal)

Connections:

76mm camlock on suction side, 76mm hose barb on the discharge side, and a 51mm male camlock for supply hose

Mounting:

Adapts easily to any truck or trailer

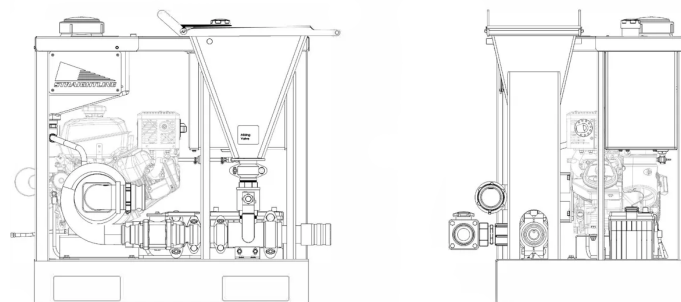

L	W	H
1101mm	855mm	1064mm

For more information, talk to us today

AUSTRALIA
03 9068 5688

NEW ZEALAND
07 849 2366

sales@blick.group
www.blick.group